

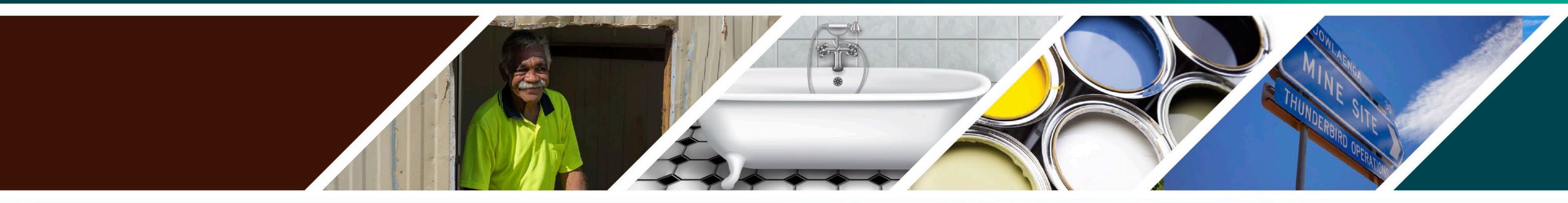

SheffieldResources
LIMITED

2021 Project Update



March 2021

ASX:SFX | sheffieldresources.com.au

Notice and Disclaimer

IMPORTANT: You must read the following in conjunction with this document.

Summary information in relation to Sheffield

This document contains summary information about Sheffield Resources Limited (ACN 125 811 083) (Company or Sheffield), its subsidiaries and their activities which is current as at the date of this document, unless otherwise indicated. The information in this document remains subject to change without notice, and Sheffield is not responsible for updating, nor does it undertake to update, it. This document should be read in conjunction with Sheffield's periodic and continuous disclosure announcements lodged with the Australian Securities Exchange (ASX), which are available at <http://www.sheffieldresources.com.au/irm/content/asx-announcements1.aspx?RID=398> or www.asx.com.au.

Industry data

Certain market and industry data used in connection with or referenced in this document, including in relation to other companies in Sheffield's peer group, may have been obtained from public filings, research, surveys or studies made or conducted by third parties, including as published in industry-specific or general publications. Neither Sheffield or their respective representatives have independently verified any such market or industry data.

Compliance Statements

Information and documentation which forms the basis of the Thunderbird Bankable Feasibility Study (BFS) and Bankable Feasibility Study Update (BFSU) in relation to Mineral Resources, Ore Reserves and metallurgy and process design has previously been reported as detailed below. The Company confirms that it is not aware of any new information or data that materially affects the information included in the relevant market announcements and, in the case of the July 2016 Thunderbird Mineral Resources and the July 2019 Thunderbird Ore Reserve, that all material assumptions and technical parameters underpinning the estimates in the relevant market announcement continue to apply and have not materially changed. In the case of the announcement entitled "BFS Update Materially Improves Project Economics" dated 31 July 2019, the Company confirms that all material assumptions underpinning any production target and any forecast financial information derived from any production target that is disclosed in this announcement continue to apply and have not materially changed. The Company confirms that the form and context of the Competent Person's findings are presented and have not been materially modified from the original market announcements.

Estimates of Mineral Resources and Ore Reserves and exploration results

This document contains estimates of Sheffield's Ore Reserve and Mineral Resources and information that relates to exploration results.

The Mineral Resources and Ore Reserves of Sheffield have been extracted from Sheffield's ASX releases;

"BFS UPDATE MATERIALLY IMPROVES PROJECT ECONOMICS" 31 July 2019

"THUNDERBIRD ORE RESERVE UPDATE" 31 July 2019

"HIGH GRADE MAIDEN MINERAL RESOURCE AT NIGHT TRAIN" 31 January 2019

"MINERAL RESOURCE AND ORE RESERVE STATEMENT" 3 October 2018

"THUNDERBIRD ORE RESERVE UPDATE" 16 March 2017

"SHEFFIELD DOUBLES MEASURED MINERAL RESOURCE AT THUNDERBIRD" 5 July 2016

The exploration results have been extracted from Sheffield's ASX releases;

"NEW LARGE HIGH GRADE DISCOVERY SOUTH OF THUNDERBIRD" 13 November 2018

"EXCEPTIONAL RESULTS CONFIRM MAJOR DISCOVERY AT NIGHT TRAIN" 9 October 2018

A copy of these announcements is available at <http://www.sheffieldresources.com.au/irm/content/asx-announcements1.aspx?RID=398> or www.asx.com.au.

Bankable Feasibility Study ("BFS")

This document contains information that relates to a Bankable Feasibility Study. This information was extracted from the following ASX releases by Sheffield:

THUNDERBIRD BFS DELIVERS OUTSTANDING RESULTS" 24 March, 2017

Other Extracted Information

In addition to those ASX releases referred to above, this document contains information extracted from the following ASX releases:

"TRANSFORMATIONAL THUNDERBIRD JOINT VENTURE" 11 August 2020

"QUARTERLY ACTIVITIES REPORT" and "QUARTERLY CASHFLOW REPORT" 13 October 2020

"NATIVE TITLE AGREEMENT SIGNED BY TRADITIONAL OWNERS" 1 November 2018

"MINING LEASE GRANTED OVER THUNDERBIRD MINERAL SANDS PROJECT" 26 September 2018

"FEDERAL ENVIRONMENTAL APPROVAL GRANTED FOR THUNDERBIRD" 28 September 2018

"STATE MINISTER FOR ENVIRONMENT APPROVES THUNDERBIRD MINERAL SANDS PROJECT" 13 August 2018

"GRANT OF MISCELLANEOUS LICENCES" 27 June 2018

"EPA COMMENDS APPROVAL OF THUNDERBIRD" 9 October 2017

"THUNDERBIRD PROJECT AND JOINT VENTURE UPDATE" 16 September 2020

"ADDITIONAL BINDING ZIRCON CONCENTRATE OFFTAKE AGREEMENT SIGNED" 22 July 2019

"SHEFFIELD SIGNS TAURUS DEBT FACILITY AND EPC CONTRACT" 12 November 2018

"NAIF APPROVES LOAN FACILITIES TOTALLING A\$95M" 19 September 2018

"NATIVE TITLE UPDATE: SHEFFIELD SIGNS CO-EXISTENCE AGREEMENT" 10 September 2018

"MAIDEN BINDING ILMENITE OFFTAKE AGREEMENT" 21 June 2018

"SHEFFIELD ANNOUNCES EPC PREFERRED CONTRACTOR" 19 October 2017

"SHEFFIELD SIGNS MAIDEN BINDING OFFTAKE AGREEMENT" 12 September 2017

The Company confirms that it is not aware of any new information or data that materially affects the information included in the relevant market announcements and, in the case of estimates of Mineral Resources and Ore Reserves, that all material assumptions and technical parameters underpinning the estimates in the relevant market announcement continue to apply and have not materially changed. The Company confirms that the form and context in which the Competent Person's findings are presented have not been materially modified from the original market announcements.

Notice and Disclaimer

Not financial product advice

This document does not constitute, and is not intended to constitute, investment or financial product advice (nor tax, accounting or legal advice). This document should not be relied upon as advice to investors or potential investors and has been prepared without taking account of any person's individual investment objectives, financial situation or particular needs. Any investment decision should be made based solely upon appropriate due diligence. Before making an investment decision, prospective investors should consider the appropriateness of the information having regard to their own investment objectives, financial situation and needs and seek legal, accounting and taxation advice appropriate to their jurisdiction. Recipients of this document are advised to consult their own professional advisers. An investment in any listed company, including Sheffield, is subject to significant risks, both known and unknown and including (without limitation) risks of loss of income and capital. A number of risks are beyond the control of Sheffield.

Effect of rounding

A number of figures, amounts, percentages, estimates, calculations of value and fractions in this document are subject to the effect of rounding. Accordingly, the actual calculation of these figures may differ from the figures set out in this document.

Financial data

All currency amounts are in Australian Dollars (\$) or A\$) unless otherwise stated.

Future performance, forward-looking statements and key risks

This document is to be read in conjunction with the information contained in Appendices and the ASX:SFX announcements on BFS Update and the Ore Reserve Update of 31 July 2019.

This document contains certain "forward-looking statements". Forward-looking statements can generally be identified by the use of forward looking words such as "forecast", "likely", "believe", "future", "project", "opinion", "guidance", "should", "could", "target", "propose", "to be", "foresee", "aim", "may", "will", "expect", "intend", "plan", "estimate", "anticipate", "continue", "indicative" and "guidance", and other similar words and expressions, which may include, without limitation, statements regarding plans, strategies and objectives of management, anticipated production dates, expected costs or production outputs for the Company, based on (among other things) its estimates of future production of the Thunderbird Project and the future operation of Sheffield and the Thunderbird Project.

To the extent that this document contains forward-looking information (including forward-looking statements, opinions or estimates), the forward-looking information is subject to a number of risk factors, including those generally associated with the mineral sands industry. Any such forward-looking statement also inherently involves known and unknown risks, uncertainties and other factors that may cause actual results, performance and achievements to be materially greater or less than estimated. These factors may include, but are not limited to, changes in commodity prices, foreign exchange fluctuations, general economic and share market conditions, increased costs and demand for production inputs, the speculative nature of exploration and project development (including the risks of obtaining necessary licenses and permits and diminishing quantities or grades of reserves), changes to the regulatory framework within which the Company operates or may in the future operate, environmental conditions including extreme weather conditions, geological and geotechnical events, and environmental issues, and the recruitment and retention of key personnel.

Any forward-looking statements are also based on assumptions and contingencies which are subject to change without notice and which may ultimately prove to be materially incorrect, as are statements about market and industry trends, which are based on interpretations of current market conditions. Investors should consider the forward-looking statements contained in this document in light of those disclosures and not place reliance on such statements. The forward-looking statements in this document are not guarantees or predictions of future performance and may involve significant elements of subjective judgment, assumptions as to future events that may not be correct, known and unknown risks, uncertainties and other factors, many of which are outside the control of Sheffield. As a result, there can be no assurance that actual outcomes will not materially differ from these forward-looking statements. The forward-looking statements are based on information available to Sheffield as at the date of this document. Except as required by law or regulation, Sheffield undertakes no obligation to provide any additional or updated information or update any forward-looking statements, whether as a result of new information, future events or results or otherwise.

Indications of, and guidance on, future performance are also forward-looking statements, and include statements in this document regarding anticipated mine life, expected or indicative costs, indicative revenues, indicative production outputs and anticipated production dates. To the maximum extent permitted by law, Sheffield, and its respective directors, officers, employees, advisers, agents and intermediaries (together, "Relevant Parties") disclaim any obligation or undertaking to release any updates or revisions to the information to reflect any change in expectations or assumptions, or any change in events, conditions or circumstances on which any such information or statement is based. Nothing in this document will, under any circumstances (including by reason of this document remaining available and not being superseded or replaced by any other document or publication with respect to Sheffield or the subject matter of this document), create an implication that there has been no change in the affairs of Sheffield since the date of this document.

To the maximum extent permitted by law, the Relevant Parties make no representation or warranty (express or implied) as to the fairness, accuracy, reliability, currency, reasonableness or completeness of the contents of this document or any other information (whether written or verbal) that the Relevant Parties otherwise provide to the recipient. The recipient may not rely on the contents of the document or any information in it in making any decision to invest or acquire an interest in the Thunderbird Project. To the maximum extent permitted by law, the Relevant Parties are not liable for any direct, indirect or consequential loss or damage suffered (whether foreseeable or not) by any person (whether arising from negligence or otherwise) as a result of relying on this document or the information in it, any errors therein or omissions therefrom, or any other written or oral communications transmitted to the recipient in the course of its evaluation of the Thunderbird Project, or otherwise in connection with this document or the information in it.

Investment risk

As noted above, an investment in Sheffield securities is subject to investment and other known and unknown risks, a number of which are beyond the control of Sheffield. Sheffield (nor its related bodies corporate) does not guarantee any particular rate of return or the performance of the Company or the Thunderbird Project, nor does it guarantee the repayment of capital from Sheffield or any particular tax treatment. Prospective investors should make their own enquiries and investigations regarding all information in this document, including but not limited to the assumptions, uncertainties and contingencies which may affect future operations of Sheffield and the Thunderbird Project and the impact that different future outcomes may have on Sheffield and the Thunderbird Project.

Not an Offer

This document is for information purposes only and does not constitute or form any part of any offer or invitation to sell or issue, or any solicitation of any offer to purchase or subscribe for, any securities in the Company in any jurisdiction. This document and its contents must not be distributed, transmitted or viewed by any person in any jurisdiction where the distribution, transmission or viewing of this document would be unlawful under the securities or other laws of that or any other jurisdiction.

Thunderbird – From JV to FID

Kimberly Mineral Sands

Board Restructure

Project Update

Market Opportunity

Pathway to FID

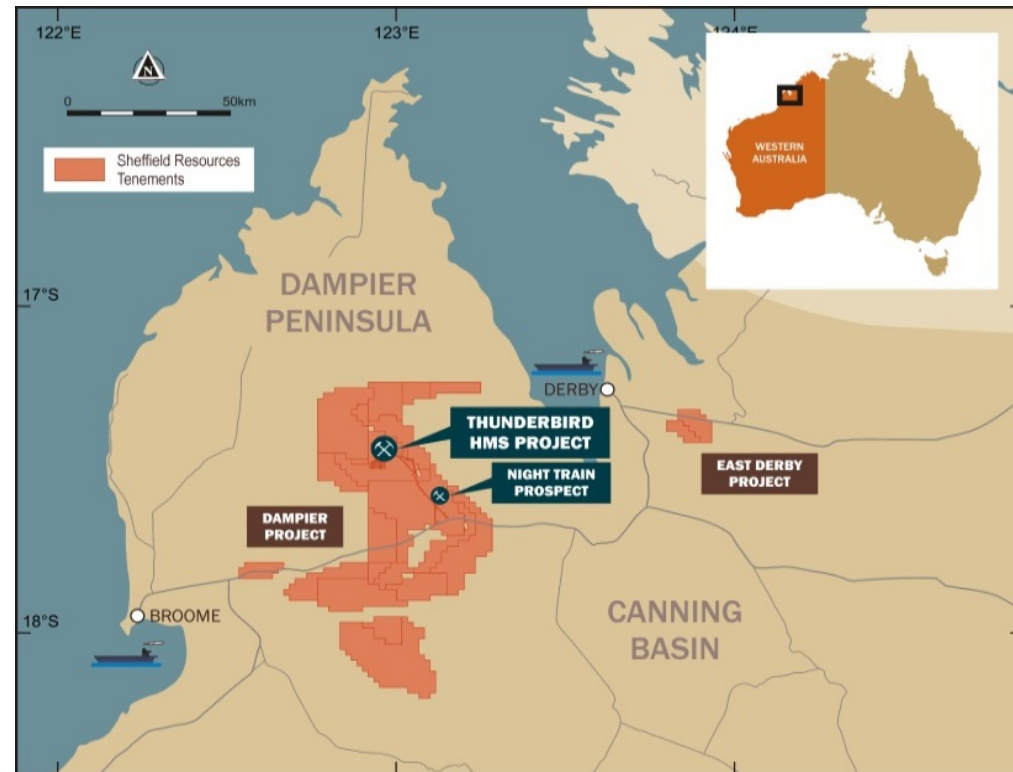

Kimberley Mineral Sands transaction completed

Kimberley Mineral Sands¹

- Yansteel contributed A\$130.1m in equity to acquire its 50% interest
- Sheffield retains 50%

Placement²

- Yansteel paid A\$12.9m for 9.9% of Sheffield in a placement completed on 12 August 2020
- The shares were issued at a 131% premium

Offtake²

- Market price, life of mine, take or pay, for 100% of the Stage 1 LTR Ilmenite
- First right of refusal at market price for 100% of ilmenite from subsequent expansions

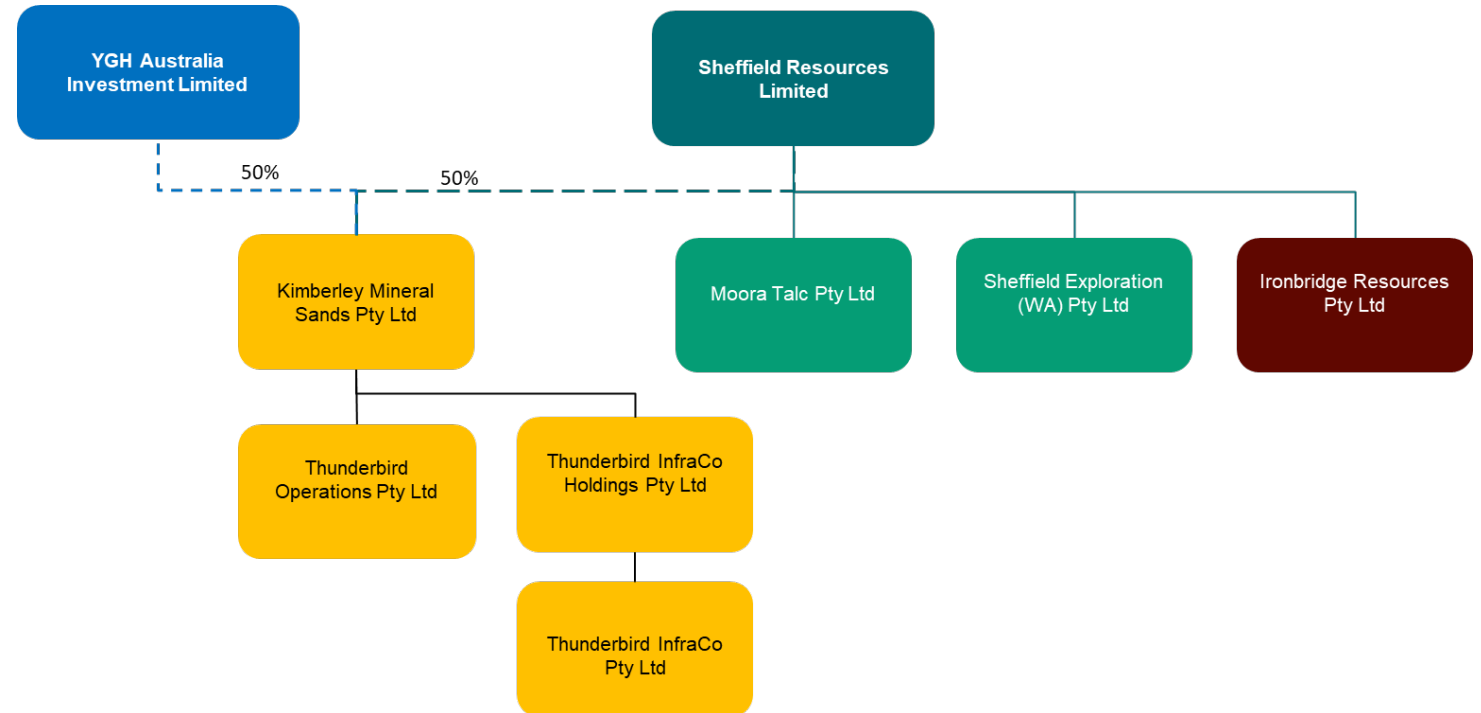

Reference:

1. ASX Announcement "Joint Venture Completion and Board Restructure" 12 March 2021
2. ASX Announcement "Transformational Thunderbird Joint Venture" 11 August 2020

Board and Management restructured for execution

Sheffield Resources Limited - Board and Management (ASX:SFX)



John Richards
Non-Executive Chairman

Economist with more than 35 years' experience in the resources industry; holding various positions within mining companies, investment banks and private equity groups.



Bruce McFadzean
Managing Director

Mining engineer with over 40 years experience leading the financing, development and operation of mines in Australia and overseas



Bruce Griffin
Commercial Director

Previously Senior VP of Strategic Development with Lomon Billions following Executive Management roles in several resource companies including acting CEO & Director of TZ Minerals Intl.



Ian MacIver
Non-Executive Director

Experienced in corporate activity including capital raisings, acquisitions, divestments, takeovers, business & strategic planning, debt & equity, financial review & valuations.



Gordon Cowe
Non-Executive Director

Mechanical engineer with over 30 years experience involved in leading business start-up, planning & delivery of multiple complex projects.



Mark Di Silvio
CFO / Company Secretary

CPA with 30 years experience in the resources sector leading both financing and project development activities across Australia and Africa

Kimberley Mineral Sands Pty Ltd – Executive Management Team



Stuart Pether
CEO - Kimberley Mineral Sands

Mining engineer with over 25 years technical and operating experience in the resources industry, both in Australia and overseas



Neil Patten-Williams
General Manager Marketing

Experienced mineral sands marketing and operations manager with over 23 years experience in the mineral sands industry.



TBA
General Manager People
Currently recruiting



Geoff Williams
General Manager Operations

Mining engineer with over 25 years mining experience in operational roles. A resident of Broome, having lived and worked in the Kimberley for many years



TBA
Project Director
Currently recruiting



TBA
CFO
Currently recruiting

One of the Largest, Highest Grade Ore Reserves Globally

Comparison of Ore Reserves and grade between the key large mineral sands deposits globally^{1,2,3}

- Large, mature mineral sands deposits globally typically show accelerating grade depletion trend with each new published Ore Reserve update
- The highest grade and most significant zircon producing mine, Jacinth-Ambrosia is nearing the end of its mine life
- Increasing throughput and production rates at mature operations are accelerating the depletion of Ore Reserves and mine life

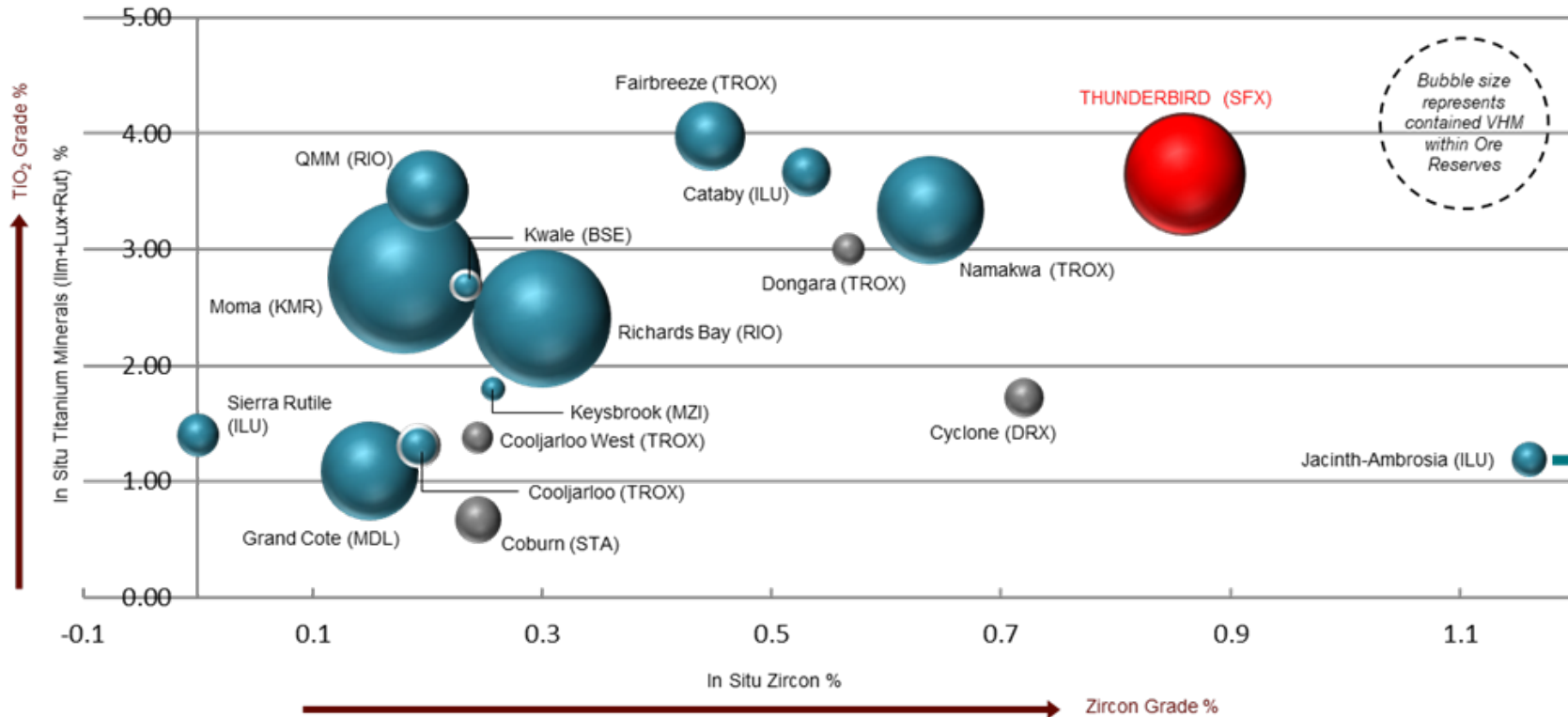

Notes:

1. Thunderbird Ore Reserve as published on the ASX on 31 July 2019. Thunderbird Ore Reserves ranked against latest published Ore Reserves of current mineral sands operations and projects under investigation globally. Accordingly, for the operating projects, no account is made for any volumes of product already produced
2. Blue bubbles are operating mines, grey bubbles are Ore Reserves reported but the project is not operating. Only Ore Reserves > 1.2Mt contained VHM shown
3. Data compiled by Sheffield from public sources. This analysis does not illustrate the variance in product value between rutile, leucoxene and ilmenite

Thunderbird – Simplified flowsheet



SheffieldResources
LIMITED

Non-mag concentrate

- Removes zircon MSP from BFS and BFSU

LTR Ilmenite

- Ilmenite circuit from BFS flowsheet

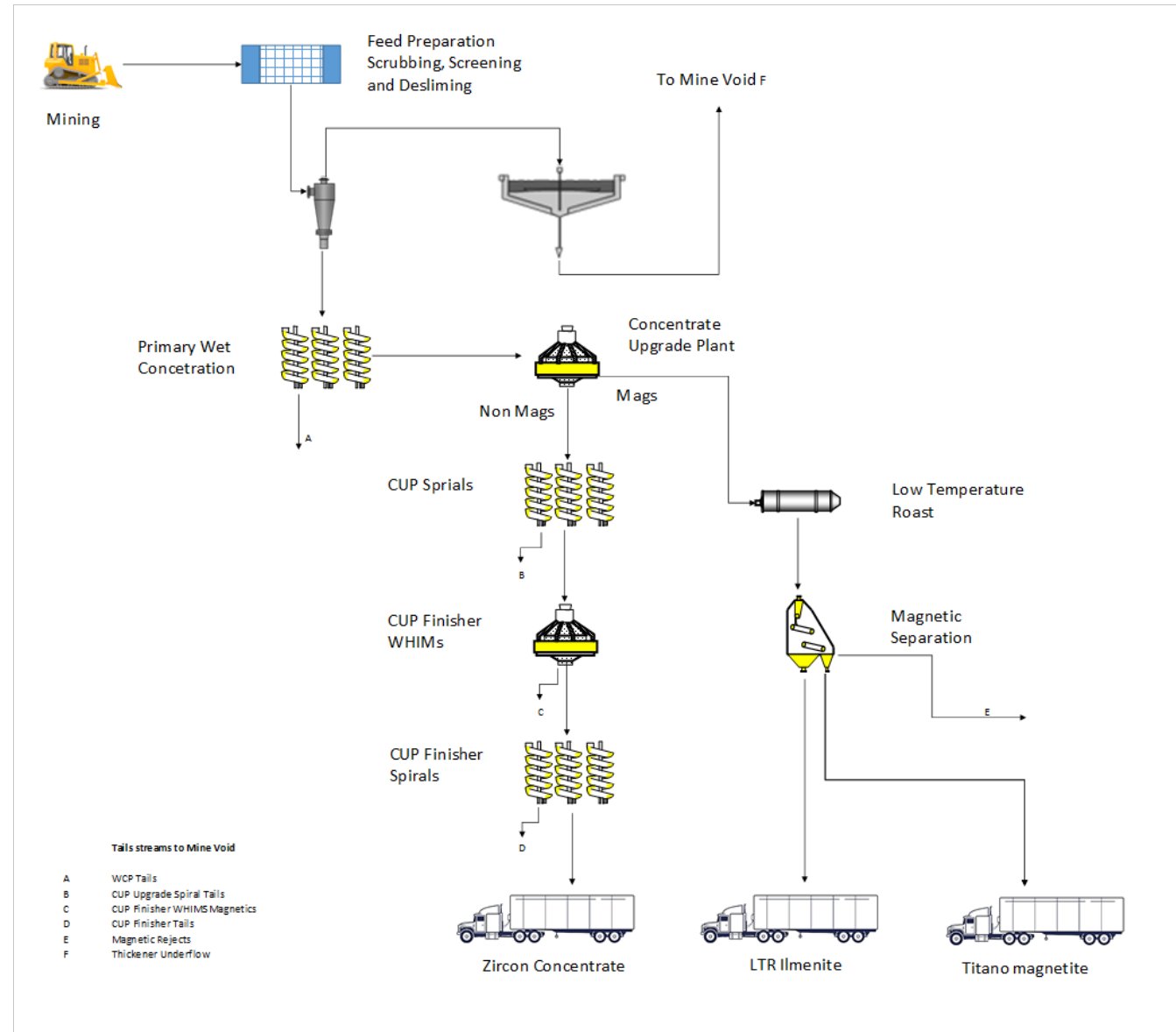

Thunderbird – Yansteel equity to fill funding gap

Process capital expected to be lower with simplified flowsheet

- + Cost of reintroduction of LTR offset by
- Simplified ilmenite circuit
- Removal of zircon MSP

JV BFS will update project capital and operating costs

Overall Project capital and financial metrics are expected to be similar to the BFSU

Yansteel equity expected to fulfil Phase 1 capital requirement

- A\$130m of JV equity from Yansteel + A\$13m from placement = A\$143m
- Debt funding previously secured through the Taurus and NAIF facilities to be reconfirmed¹

Option		Project Capital A\$m	Total Funding A\$m	Ungearred	
				NPV ₈ Post Tax A\$m	IRR Post Tax
BFS	LTR Ilmenite + Full MSP	463 ²	579 ²	620 ²	21%
BFSU	Ilmenite Concentrate + Full MSP	392 ³	478 ³	980 ³	30%
JV BFS	LTR Ilmenite + Non-Mag Concentrate	TBC	TBC	TBC	TBC

Reference:

1. ASX Announcement "Sheffield Signs Taurus Debt Facility and EPC Contract" 12 November 2018
2. ASX Announcement "Thunderbird BFS Delivers Outstanding Results" 24 March 2017
3. ASX Announcement "BFS Update Materially Improves Project Economics" 31 July 2019

Thunderbird – Trial mining confirms mining method and cost



SheffieldResources
LIMITED



- Trial Mining Program was completed in Q4 2020. The pit was 220kt containing 120kt of ore and 100kt of waste material.
- Trial pit was 30m deep and mined through the high grade T2 ore zone c. 21m thick.
- Program successfully completed with small scale equipment, being:
 - 1x 70t excavator,
 - 1 x D9 dozer and
 - 3 x 65t trucks
- A 25t bulk ore sample was taken for scrubber and MUP design test work
- Geotechnical mapping for wall design parameters was completed

Thunderbird – Attractive product mix

- **LTR Ilmenite**

- 400,000² tonnes per annum in Phase 1
- Suitable for TiO₂ slag or sulphate pigment feedstock
- 53% TiO₂ and low in key contaminants
- 100% binding offtake with Yansteel

- **Titano-magnetite**

- 300,000² tonnes per annum in Phase 1
- 55% Fe, 15% TiO₂; 90% Iron Oxides + TiO₂

- **Non-Magnetic Concentrate**

- 210,000² tonnes per annum in Phase 1
- 39% ZrO₂, 25% TiO₂
- ~40% of zircon recoverable as premium with standard processing
- Offtake discussions to be conducted with customers

Projected First Four Full Production Years

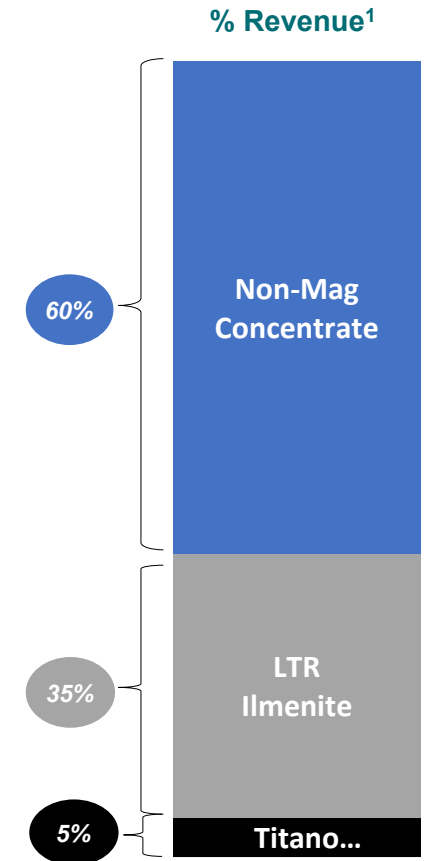
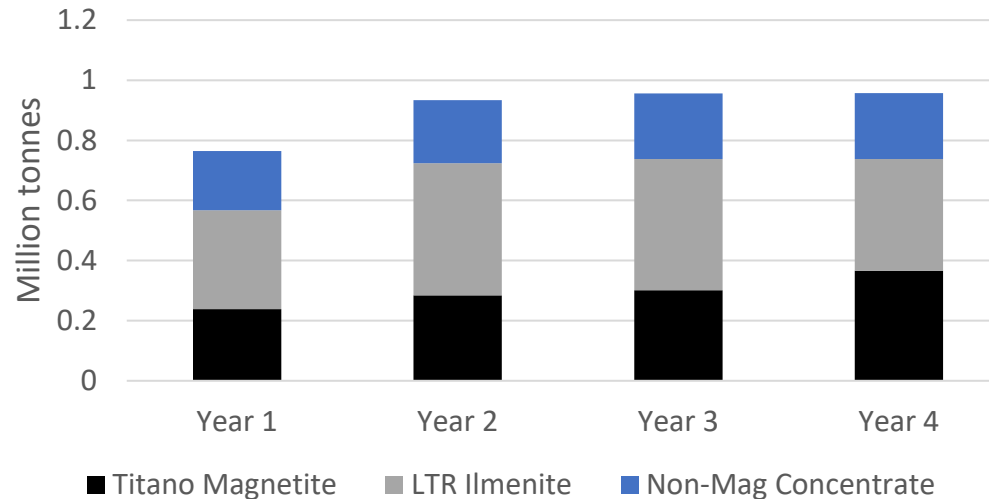

Note
¹ Indicative
² Average annual tonnage of first 4 years of stage 1 production

Thunderbird – Aligned with emerging zircon supply gap

Zircon supply gap forecast from 2021/22 onwards

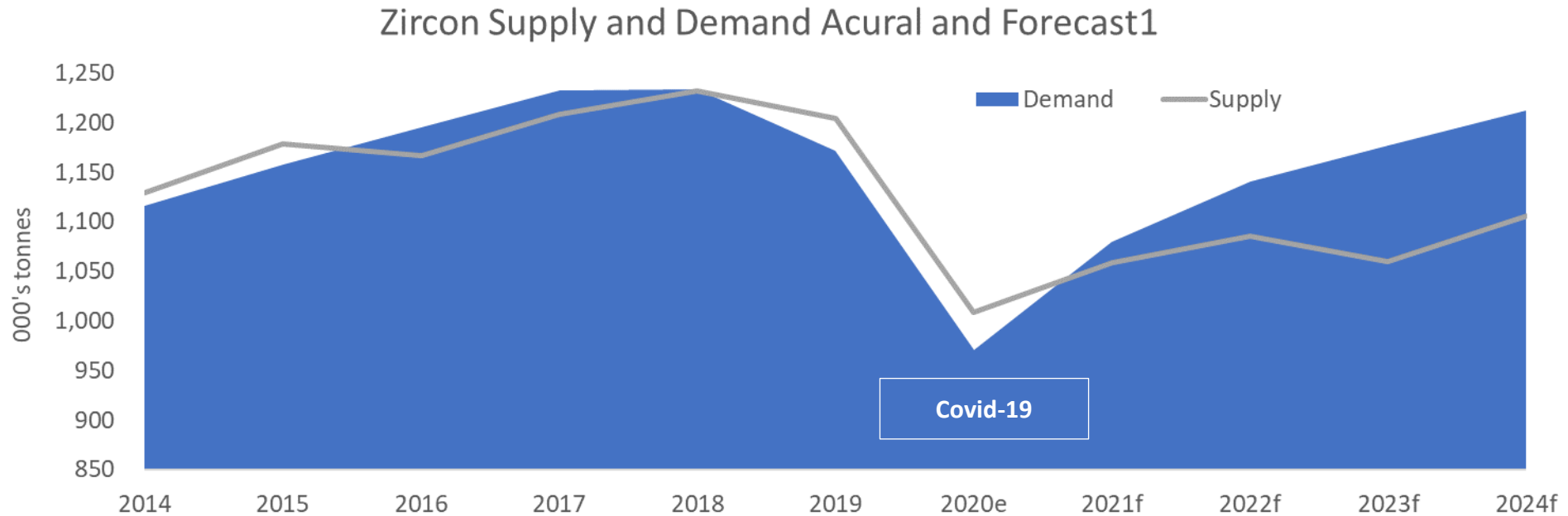

Observations

- Covid-19 2020 demand impact significant but less than predicted
- Major suppliers have adjusted supply to match reduced demand
- This supply response eased the pressure on price
- Supply deficit forecast from late 2021 onwards
- Ore Reserve depletion and jurisdictional risks
- Mid-term shortfall is supply not demand driven

Note:
1. Sourced from TZMI and Sheffield estimates

Thunderbird – New ilmenite supply is required

New non-captive projects required to meet non-captive demand

Sulfate Ilmenite Supply and Demand Actual and Forecast ^{1,2}

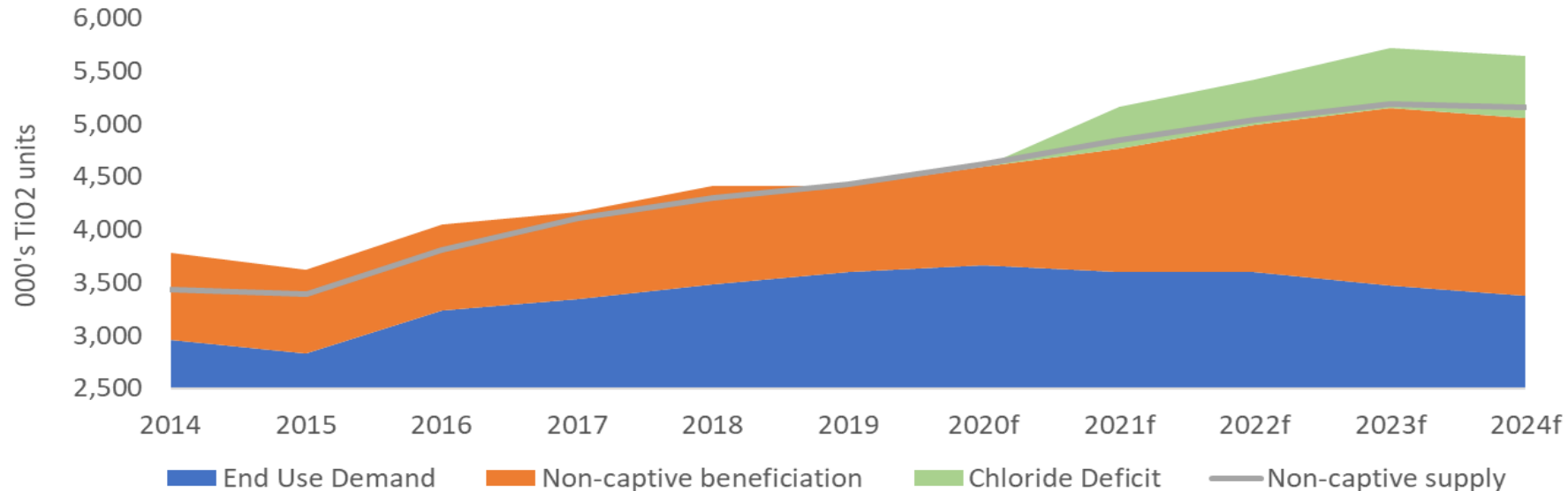

Observations

- Sulfate ilmenite demand remained strong during 2020
- Sulfate pigment provides solid demand base
- New Chinese chloride slag smelters driving increasing beneficiation demand
- Chloride feedstock deficit most likely to be filled by additional chloride slag capacity – driving further ilmenite demand
- Non-captive supply deficit emerges from 2023 unless new projects are developed

Note:
1. End Use includes Sulfate Pigment and Other Sectors that consume sulfate ilmenite without upgrading to slag
2. Sourced from TZMI May 2020 and Sheffield estimates

Pathway from Joint Venture to FID

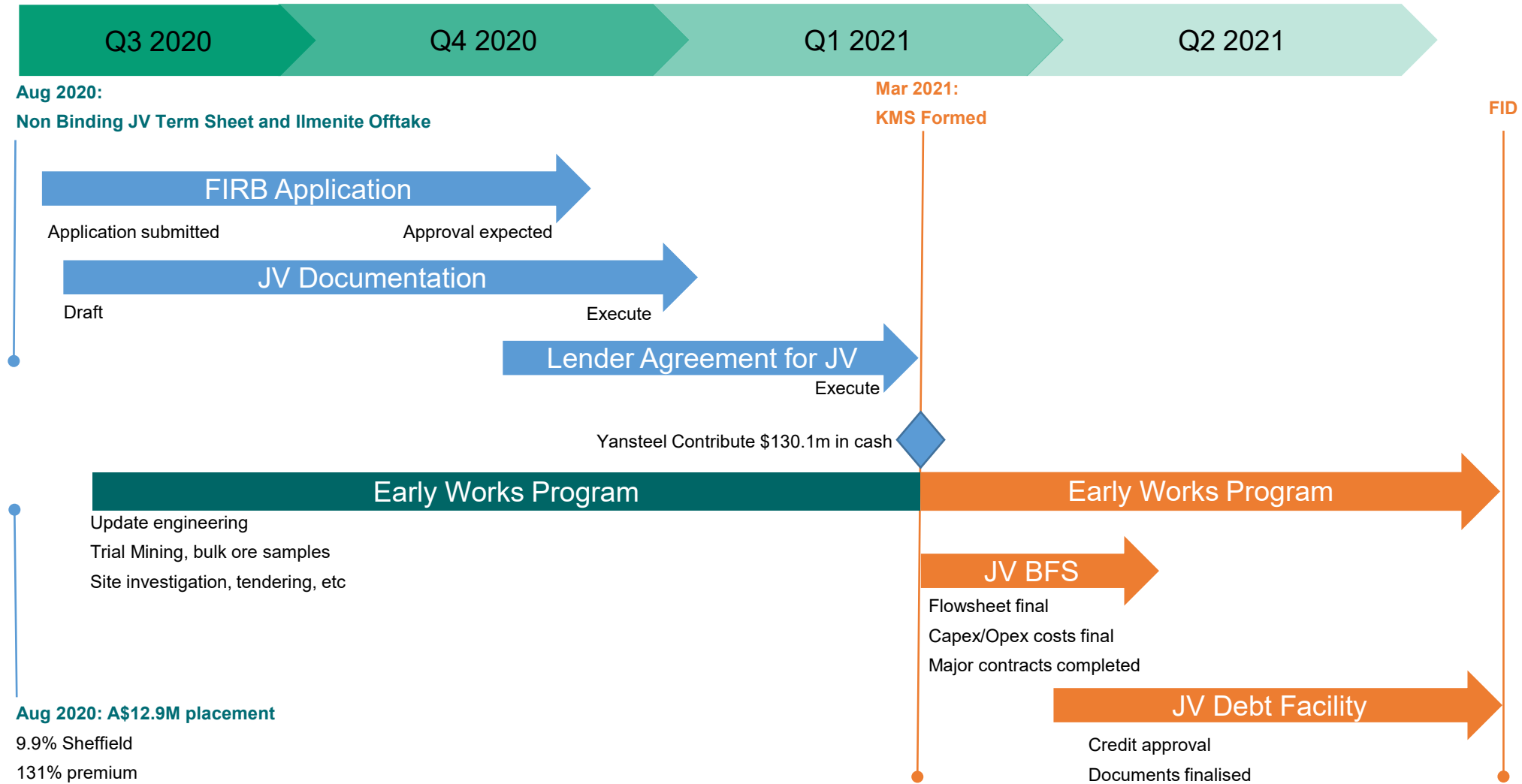

Aug 2020: A\$12.9M placement

9.9% Sheffield

131% premium

Note:

1. All timelines are estimated and subject to further study and confirmation

Summary

- Kimberly Mineral Sands (KMS) formed on 12 March
- KMS cash balance A\$130.1m
- Thunderbird targeted to be a large, long life zircon and ilmenite producer
- Overall project capital and financial metrics are expected to be similar to the BFSU
- Cash on hand + reconfirmed debt expected to fulfil Stage 1 funding requirement
- Australia is a very stable mining jurisdiction
- Thunderbird is fully permitted
- Global zircon supply gap from 2021/2022
- New ilmenite supply required to meet rising pigment and chloride slag demand
- Pathway to FID with target to commence construction during 2021 dry season

APPENDIX: Sheffield Resources Corporate Overview



Sheffield Resources is an ASX listed mineral sands developer which owns 100% of the large scale shovel ready Thunderbird Mineral Sands Project

- Sheffield Resources Limited (“Sheffield” or the “Company”) is an ASX listed mineral sands developer and explorer based in Perth, Western Australia (ASX:SFX)
- Sheffield is focused on the development of the 50% owned Thunderbird Mineral Sands Project (“Thunderbird” or the “Project”) located on the Dampier Peninsula in Northern Western Australia.
- Thunderbird has been developed as a greenfield project since discovery in 2012 and is one of the largest and highest grade zircon rich discoveries in the last 30 years and is one of a few greenfield mineral sands deposits globally in a secure jurisdiction
- Experienced and skilled Board and management (>150 years’ collective experience) with strong in-house intellectual property and knowledge and capable of developing, delivering and operating Thunderbird
- Sheffield has a portfolio of mineral sands assets in Australia with a focus on zircon rich assemblages which includes:
 - Thunderbird with Ore Reserve of 748Mt @11.2%HM²
 - Night Train deposit, 20km to the east of Thunderbird and with an Inferred Mineral Resource³ of 130Mt @ 3.3% HM, containing 3.6Mt of VHM
 - Dampier Project has delineated 14 zones of significant mineralisation along a 160km long highly mineralised trend⁴

Capital structure¹

Item	Unit	Value
Ordinary Shares Outstanding (as at 22 Mar 2021)	#m	346
Share Price (as at 22 Mar 2021) ¹	A\$/sh	0.40
Market Capitalisation	A\$m	138.4
Cash Balance (31 December 2020)*	A\$m	12.9
Debt	A\$m	-
Enterprise Value	A\$m	125.5

*Cash balance excludes joint venture proceeds of \$130.1m as at 12 March 2021

Share Price Information

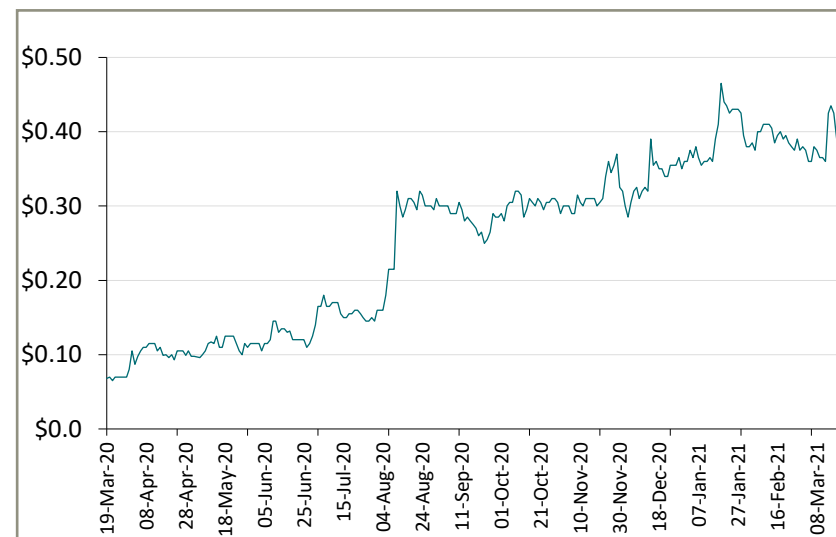

1. Market data as at 22 March 2021 and sourced from ASX
 2. Refer to ASX announcement 31 July 2019 titled “Thunderbird Ore Reserve Update”
 3. Refer to ASX announcement 31 January 2019 titled “High Grade Maiden Mineral Resource at Night Train”
 4. Refer to ASX announcement 13 November 2018 titled “New Large High Grade Discovery South of Thunderbird”

APPENDIX: Thunderbird Ore Reserves

Thunderbird Ore Reserves: Valuable Heavy Mineral in-situ grade¹

Ore Reserve Category	Ore Tonnes (Mt)	In-situ HM Tonnes (Mt)	HM Grade (%)	Valuable Heavy Mineral Grade (In-situ) ²					
				Zircon (%)	HiTi Leucoxene (%)	Leucoxene (%)	Ilmenite (%)	Oversize (%)	Slimes (%)
Proved	219	30.0	13.7	1.02	0.30	0.28	3.68	14.0	16.1
Probable	529	53.4	10.1	0.79	0.27	0.27	2.87	10.5	14.5
Total	748	83.8	11.2	0.86	0.27	0.27	3.11	11.6	15.0

Thunderbird Ore Reserves: Mineral assemblage as percentage of HM grade¹

Ore Reserve Category	Ore Tonnes (Mt)	In-situ HM Tonnes (Mt)	HM Grade (%)	Mineral Assemblage ³					
				Zircon (%)	HiTi Leucoxene (%)	Leucoxene (%)	Ilmenite (%)	Oversize (%)	Slimes (%)
Proved	219	30.0	13.7	7.4	2.2	2.0	26.9	14.0	16.1
Probable	529	53.4	10.1	7.8	2.6	2.7	28.4	10.5	14.5
Total	748	838	11.2	7.7	2.4	2.4	27.8	11.6	15.0

Notes:

- Ore Reserves are presented both in terms of in-situ VHM grade, and HM mineral assemblage. Tonnes and grades have been rounded to reflect the relative accuracy and confidence level of the estimate, thus the sum of columns may not equal. Ore Reserves reported for the Dampier Project were prepared and first disclosed under the JORC Code (2012). Refer to Sheffield's ASX Announcement dated 31 July 2019 titled "Thunderbird Ore Reserve Update" for further detail. Ore Reserve is reported to a design overburden surface with appropriate consideration for modifying factors, costs, mineral assemblage, process recoveries and product pricing
- The in-situ grade is determined by multiplying the HM Grade by the percentage of each valuable heavy mineral within the heavy mineral assemblage
- Mineral Assemblage is reported as a percentage of HM Grade. It is derived by dividing the in-situ grade by the HM grade

APPENDIX: Thunderbird Mineral Resources

Thunderbird Mineral Resources: Valuable Heavy Mineral in-situ grade¹

Cut-off (HM%)	Mineral Resource Category	Ore Tonnes (Mt)	In-situ HM Tonnes (Mt)	HM Grade ² (%)	Valuable Heavy Mineral Grade (In-situ) ³					
					Zircon (%)	HiTi Leucoxene (%)	Leucoxene (%)	Ilmenite (%)	Slimes (%)	Oversize (%)
> 3% HM	Measured	510	45	8.9	0.71	0.20	0.19	2.4	18	12
	Indicated	2,120	140	6.6	0.55	0.18	0.20	1.8	16	9
	Inferred	600	38	6.3	0.53	0.17	0.20	1.7	15	8
	Total	3,230	223	6.9	0.57	0.18	0.20	1.9	16	9
>7.5% HM	Measured	220	32	14.5	1.07	0.31	0.27	3.9	16	15
	Indicated	640	76	11.8	0.90	0.28	0.25	3.3	14	11
	Inferred	180	20	10.8	0.87	0.27	0.26	3.0	13	9
	Total	1,050	127	12.2	0.93	0.28	0.26	3.3	15	11

Thunderbird Mineral Resources: Mineral assemblage as percentage of HM grade¹

Cut-off (HM%)	Mineral Resource Category	Ore Tonnes (Mt)	In-situ HM Tonnes (Mt)	HM Grade ² (%)	Mineral Assemblage ⁴					
					Zircon (%)	HiTi Leucoxene (%)	Leucoxene (%)	Ilmenite (%)	Slimes (%)	Oversize (%)
> 3% HM	Measured	510	45	8.9	8.0	2.3	2.2	27	18	12
	Indicated	2,120	140	6.6	8.4	2.7	3.1	28	16	9
	Inferred	600	38	6.3	8.4	2.6	3.2	28	15	8
	Total	3,230	223	6.9	8.3	2.6	2.9	28	16	9
>7.5% HM	Measured	220	32	14.5	7.4	2.1	1.9	27	16	15
	Indicated	640	76	11.8	7.6	2.4	2.1	28	14	11
	Inferred	180	20	10.8	8.0	2.5	2.4	28	13	9
	Total	1,050	127	12.2	7.6	2.3	2.1	27	15	11

Notes:

- The Thunderbird Mineral Resources are reported inclusive of (not additional to) Ore Reserves. The Mineral Resource reported above 3% HM cut-off is inclusive of (not additional to) the Mineral Resource reported above 7.5% HM cut-off. All tonnages and grades have been rounded to reflect the relative accuracy and confidence level of the estimate and to maintain consistency throughout the table, therefore the sum of columns may not equal. The Mineral Resource estimate was prepared and first disclosed under the JORC Code (2012). Refer to Sheffield's ASX announcement dated 5 July 2016 titled "Sheffield Doubles Thunderbird Measured Mineral Resource" for further detail
- Total heavy minerals (HM) is within the 38µm to 1mm size fraction and has been reported as a percentage of the total material quantity
- The Valuable HM in-situ grade is reported as a percentage of the total material quantity and is determined by multiplying the percentage of total HM by the percentage of each valuable heavy mineral within the HM assemblage at the resource block model scale
- The Mineral Assemblage is represented as the percentage of HM grade. Estimates of mineral assemblage are determined by screening and magnetic separation. Magnetic fractions were analysed by QEMSCAN for mineral determination as follows: >90% liberation; ilmenite 40-70% TiO₂; leucoxene 70-94% TiO₂; high titanium leucoxene (HiTi Leucoxene) >94% TiO₂ and zircon 66.7% ZrO₂+HfO₂. The non-magnetic fraction was analysed by XRF and minerals determined as follows: Zircon ZrO₂+HfO₂/0.667 and HiTi Leucoxene TiO₂/0.94

APPENDIX: Primary Approvals, Leases & Agreements in Place

Thunderbird is fully permitted and construction ready

Party	Topic	Scope	Date Complete	In Place
Dept of Environment & Energy (Cwth)	<i>Environmental Approval</i>	Federal Government environmental approval for project	Sep 2018	<input checked="" type="checkbox"/>
Department of Water & Environmental Regulation (WA)	<i>Environmental Approval</i>	State Government environmental approval for project	Aug 2018	<input checked="" type="checkbox"/>
	<i>Works Approvals</i>	Minor or preliminary works (MoPW) – trial mining pits	Sep 2017	<input checked="" type="checkbox"/>
		Approval for mining, processing, sewage facility and waste	Aug 2018	<input checked="" type="checkbox"/>
	<i>Licence to Take Water</i>	Groundwater license for project construction and operations	Oct 2018	<input checked="" type="checkbox"/>
Department of Mines, Industrial Regulation & Safety (WA)	<i>Mining Lease</i>	• Tenure for mining and processing	Sep 2018	<input checked="" type="checkbox"/>
		• Final Stage 1 mining proposal & mine closure plan granted	Sep 2019	<input checked="" type="checkbox"/>
		• Final Stage 1 works approval granted	Oct 2019	<input checked="" type="checkbox"/>
	<i>Miscellaneous Licences</i>	Tenure for infrastructure, roads and accommodation	Jun 2018	<input checked="" type="checkbox"/>
Shire of Derby & West Kimberley	<i>Port of Derby Lease</i>	Tenure for facilities at Port of Derby	May 2018	<input checked="" type="checkbox"/>
Native Title Claimants	<i>Aboriginal Heritage Agreements</i>	Heritage protocols for exploration tenure	Nov 2015	<input checked="" type="checkbox"/>
	<i>Native Title Agreements</i>	Agreed terms and conditions for project operations	Oct 2018	<input checked="" type="checkbox"/>

APPENDIX: Kimberley Mineral Sands

Kimberly Mineral Sands

- In January 2021, Sheffield and Yansteel executed binding agreements for the formation of a 50:50 Joint Venture (Kimberly Mineral Sands Pty Ltd, KMS)
- KMS owns and will develop the Thunderbird Mineral Sands Project and adjacent tenements on the Dampier Peninsula
- The parties have agreed that the development concept for Stage 1 of the Project will be a 10.4mt per annum mine and process plant producing a zircon rich non-magnetic concentrate and LTR ilmenite.
- Yansteel contributed A\$130.1m to acquire its 50% interest in the Joint Venture.
- Sheffield will fund project equity between A\$130.1m and A\$143m, less project costs incurred prior to a Final Investment Decision (FID).
- KMS is governed by a four person Board of Directors with Sheffield and Yansteel each nominating two directors.
- Key Joint Venture decisions will require unanimous approval of both Yansteel and Sheffield.
- If required, project equity in excess of A\$143 million will be funded 50:50 by Yansteel and Sheffield.
- KMS operates as a standalone entity with its own management and employees.

Placement

- Approximately 34.3m fully paid ordinary shares (9.9% of Sheffield's issued ordinary shares) were issued to Yansteel on 12 August 2020.
- The shares were issued at A\$0.376 per share a 131% premium to Sheffield's 10-day VWAP prior to the placement.

Offtake

- Market price, life of mine, take or pay, for 100% of the Stage 1 LTR Ilmenite.
- First right of refusal at market price for 100% of ilmenite from subsequent expansions.
- In the unlikely event the Joint Venture cannot be formed, the offtake will become a 7 year, renewable for 3 years, market price take or pay, offtake agreement for 100% of the ilmenite produced from Stage 1 of the Project.

Yansteel

- Yansteel is a wholly-owned subsidiary of Tangshan Yanshan Iron & Steel Co., Ltd a privately owned steel company headquartered in Hebei, China
- Tangshan produces around 10mt per annum of steel products and has annual revenues of ~A\$6bn
- Tangshan has commenced construction of a 500ktpa integrated titanium dioxide processing facility
- This complex will consume the Low Temperature Roast ("LTR") ilmenite offtake from Stage 1 of the Thunderbird Mineral Sands Project

APPENDIX: Bankable Feasibility Study Update (BFSU)¹

Metric	2019 BFSU
NPV ₈ post-tax	A\$0.98B
IRR post-tax %	24.0%
NPV ₁₀ pre-tax	A\$1.13B
IRR pre-tax %	30.1%
Total Funding Requirement	A\$478m
Project Debt (Taurus & NAIF)	A\$335m
Equity Requirement	A\$143m
Project Capital	A\$392m
Offtake (Stage 1 binding take or pay)	~100%
Mine Life	37 years
Long Term Average FX Rate (A\$/US\$)	0.75
Revenue to Cost Ratio (yrs 1 – 10)	>2.3
EBITDA Stage 1 & 2 (years 5 – 10)	A\$250m

- c. A\$1 billion post tax NPV₈
- 24% post tax IRR
- A\$1.1 billion pre-tax NPV₁₀
- 30% pre-tax IRR
- 2.3 Revenue to cost ratio
- A\$131m annual EBITDA years 1 - 4
- A\$250m annual EBITDA years 5 - 10
- A\$335m long tenor debt
 - Taurus US\$175m (7 year tenor)
 - NAIF A\$95m (15 & 20 year tenor)
- A\$143m equity gap includes all funding costs
- Final funding/partner process well advanced
- 100% stage 1 binding off-take agreements signed
- 37 year mine life
- TZMI long term commodity pricing
- Conservative exchange rate

Reference:
1. ASX Announcement "BFS UPDATE MATERIALLY IMPROVES PROJECT ECONOMICS" 31 July 2019

Registered and Corporate Office

Sheffield Resources Ltd

Level 2

41-47 Colin Street

West Perth WA 6005

p. +61 8 6555 8777

e. info@sheffieldresources.com.au



APPENDIX: Significant Regional Exploration Upside



SheffieldResources
LIMITED

Strategic value demonstrated through multiple discoveries made along a 160km long trend

- Exploration has delineated 14 zones of significant mineralisation along a 160km long highly mineralised trend which extends from Seagull in the north to Runaway in the south¹
- Maiden high grade Mineral Resource¹ outlined at Night Train
- Three substantial new mineral sands discoveries have been outlined at Buckfast, Bohemia and Concorde
 - Characterised by broad sheet-like geometries, thick intersections
 - Mineral assemblages with high proportions of VHM dominated by leucoxene, altered ilmenite and zircon with low to moderate levels of trash
- Opens up a new 60km long highly prospective corridor south of Thunderbird
- Thick high grade intervals² have been intersected, including;
 - 46.5m @ 5.50% HM from 57.0m (NLAC025), including 21.0m @ 9.12% HM from 64.5m (Buckfast)
 - 37.5m @ 5.01% HM from 67.5m (NLAC027), including 25.5m @ 5.74% HM from 75m (Buckfast)
- Numerous zircon-rich targets identified for follow-up drilling

Buckfast – Cross Section³

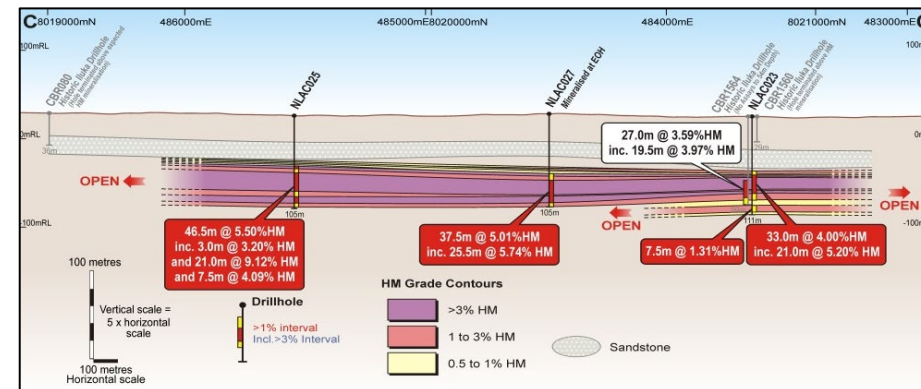

Notes:

1. Refer to ASX announcement 31 January 2019 titled "High Grade Maiden Mineral Resource at Night Train"
2. Tenements correct as of 31 December 2019, refer to "Quarterly Activities Report for the Period Ended 3 September 2020" for the latest Tenement Interests
3. Refer to ASX announcement 13 November 2018 titled "New Large High Grade Discovery South of Thunderbird"

Dampier Project – Regional Plan^{1,2}

